



**ANNOVI  
REVERBERI**  
The Power of Experience

**ANNOVI REVERBERI S.p.A.**  
Via M. L. King, 3 - 41100 Modena (Italy)  
Tel. (+39) 059.414.411 - Telefax (+39) 059.253.505  
E - Mail: industria@annovireverberi.it

**Pump type**  
**Type de pompe**  
**Pumpetyp**  
**Tipo de bomba**  
**Tipo pompa**

**XW**



**TECHNICAL DATA / DONNEES TECHNIQUES / TECHNISCHE ANGABEN**  
**CARACTERISTICAS TECNICAS / CARATTERISTICHE TECNICHE**

PUMP TYPE TYPE DE POMPE PUMPETYP TIPO DE BOMBA TIPO POMPA	CAPACITY DEBIT LEISTUNG CAUDAL PORTATA		PRESSURE PRESSION DRUCK PRESION PRESSIONE		POWER PUISSANCE KRAFT POTENCIA POTENZA		RPM TOURS/1' U.P.M. REVOLUCIONES/1' N° GIRI/1'	WEIGHT POIDS GEWICHT PESO PESO
	l/min	gpm (US)	bar	psi	HP	kW		
XW 15.15	15	3.96	150	2200	5.5	4	1450	16
XW 15.20	15	3.96	200	2900	7.5	5.5	1450	16
XW 15.30	15	3.96	300	4350	12	8.7	1450	16
XW 21.20	21	5.55	200	2900	10	7.5	1450	16
XW 21.25	21	5.55	250	3600	12.5	9.2	1450	16
XW 21.28	21	5.55	280	4060	15	11	1450	16
XW 26.12	26	6.87	120	1740	7.5	5.5	1450	16
XW 26.15	26	6.87	150	2200	10	7.5	1450	16
XW 26.20	26	6.87	200	2900	12.5	9.2	1450	16
XW 26.23	26	6.87	230	3400	15	11	1450	16
XW 30.10	30	7.92	100	1450	7.5	5.5	1450	16
XW 30.15	30	7.92	150	2200	10	7.5	1450	16
XW 30.20	30	7.92	200	2900	15	10	1450	16
XW 30.25	30	7.92	250	3600	19	14	1450	16



**ATTENTION:**  
**ATTENCIÓN:**  
**ACHTUNG:**  
**ATTENZIONE:**

- This manual must be read before beginning installation of the unit.
- Ce livret doit être lu avant d'installer et d'employer le produit.
- Das vorliegende Handbuch ist vor der Installation und dem Gebrauch des Produkts aufmerksam zu lesen.
- Este manual debe ser leído antes de proceder a la instalación y uso del producto.
- Il presente libretto va letto prima di procedere all'installazione ed uso del prodotto.

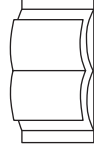

cod. 99175-DZ

# XW

VERSION

# N

# 1450rpm

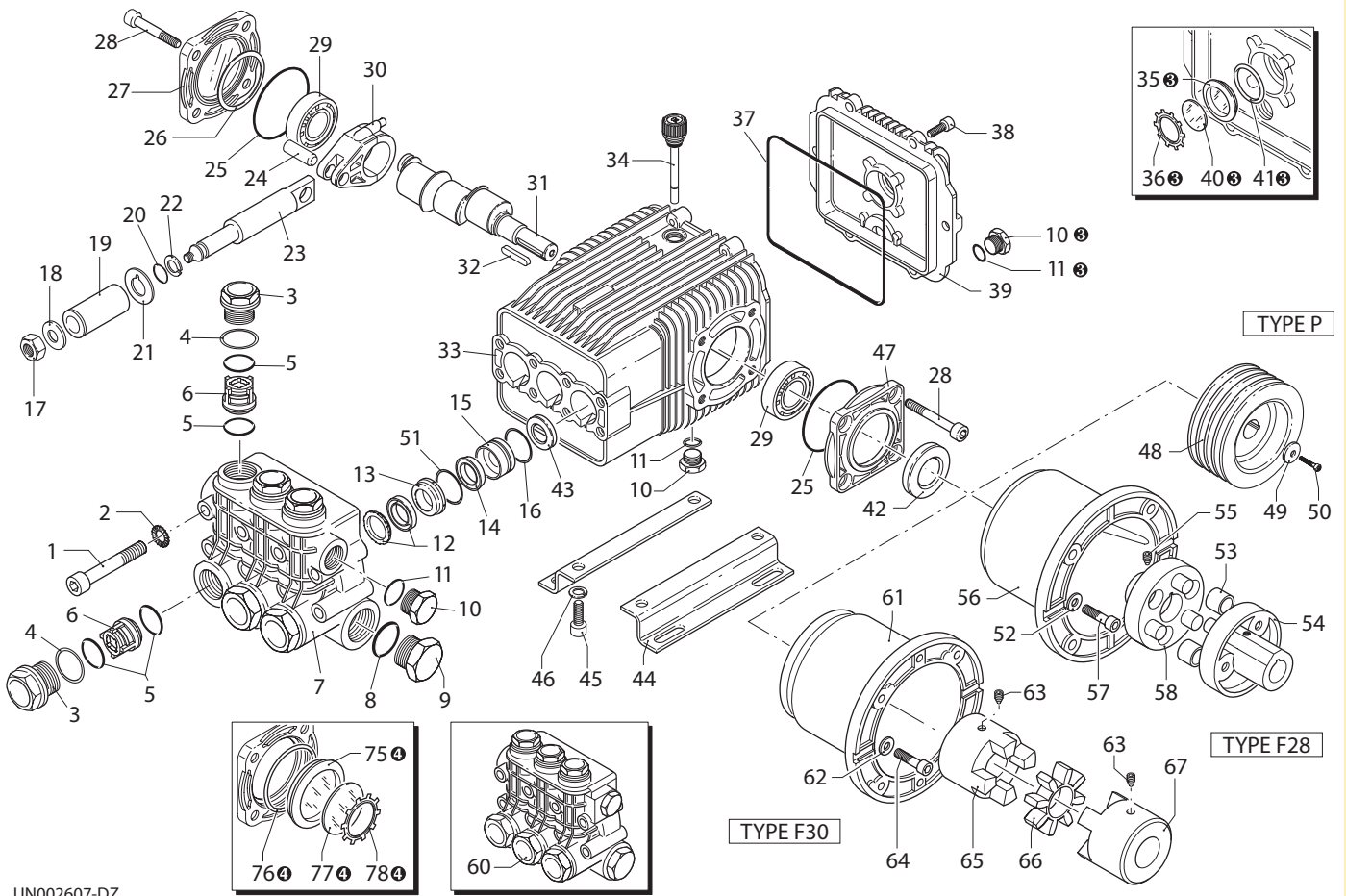

UN002607-DZ

## KIT RICAMBI / PART KITS

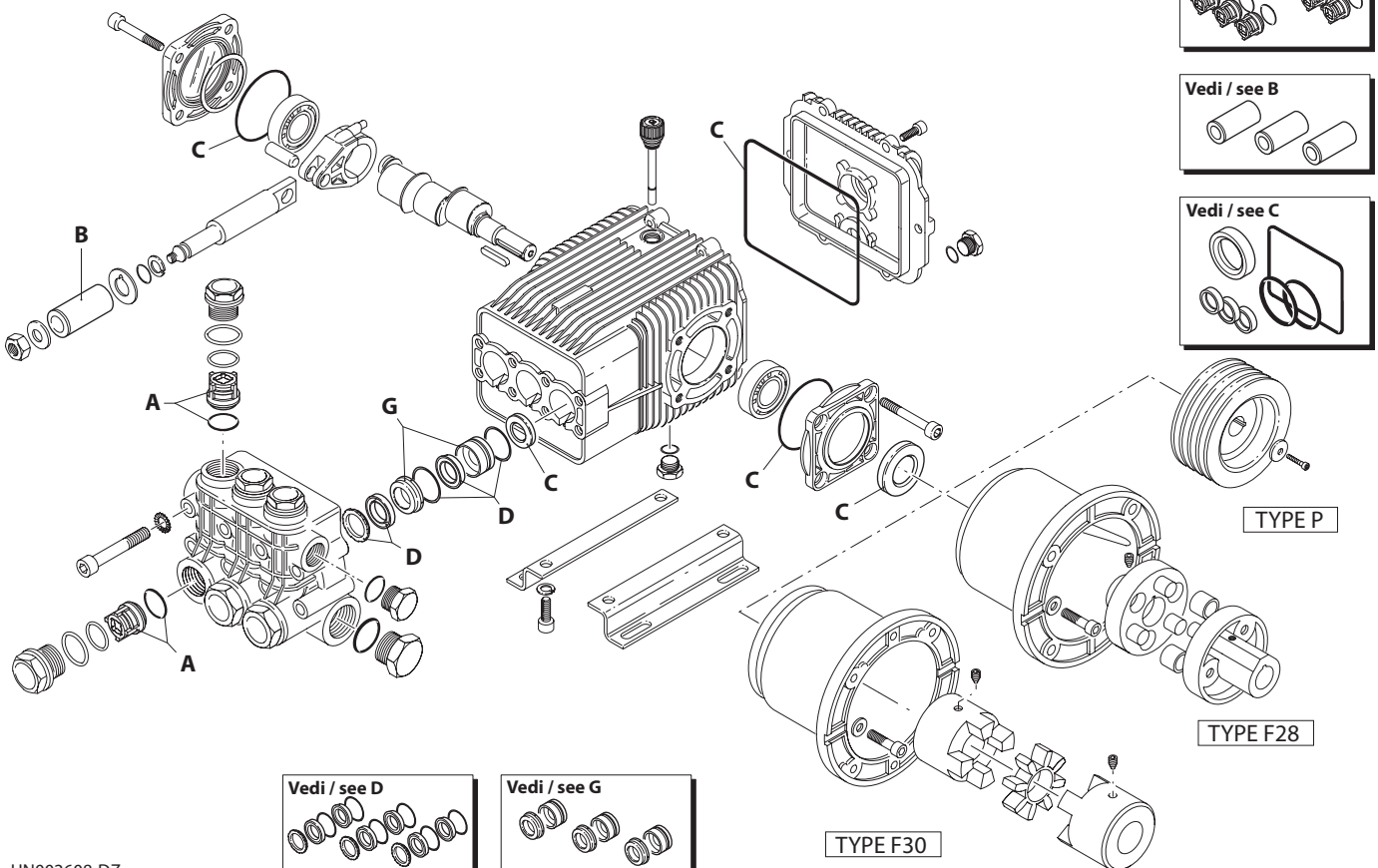

UN002608-DZ

# XW

# VERSION N

**MODELLO - MODEL:**

15.15	15.20	15.30	21.20	21.25
21.28	26.12	26.15	26.20	26.23
30.10	30.15	30.20	30.25	



Pos.	Cod. Part n°	Denominazione	Description	Q.tà Q.ty	Note Vedi / See	Pos.	Cod. Part n°	Denominazione	Description	Q.tà Q.ty	Note Vedi / See
1	1940260	Vite TCEI M 10x80	Screw	8		32	650250	Linguetta	Key	1	
2	650530	Rosetta	Washer	8		33	1941330	Corpo pompa	Pump housing	1	
3	1940140	Tappo	Plug	6		34	1140370	Tappo olio	Oil cap	1	
4	1940150	Anello	Ring	6		35	1260250	Livello olio	Oil indicator	1	⊗
5	1140450	OR ø 20,24x2,62	O-Ring	12		36	1260430	Anello elastico	Snap ring	1	⊗
6	1949050	Valvola completa	Complete valve	6		37	1940410	OR ø 132x3	O-Ring	1	
7	1940021	Testa pompa	Pump head	1	● ◆ ○ ■	38	1200430	Vite TCEI M 6x16	Screw	6	
	1941210	Testa pompa	Pump head	1	▲	39	1949010	Cop. post. compl.	Complete cover	1	
8	550350	OR ø 23,81x2,62	O-Ring	1		40	1780690	Disco di contrasto	Disc	1	⊗
9	1140300	Tappo 3/4" G	Plug	1		41	1140450	OR ø 20,24x2,62	O-Ring	1	⊗
10	1980740	Tappo 3/8" G	Plug	3	⊗	42	820680	Anello tenuta	Seal	1	
11	740290	OR ø 14x1,78	O-Ring	3	⊗	43	1940560	Anello tenuta	Seal	3	
12	1940440	Guarn.+anello	Gasket w/ ring	3	∅ 20 ● ◆ ○ ■	44	1940370	Piede	Base	2	Optional
	1940270	Guarn.+anello	Gasket w/ ring	3	∅ 22 ▲	45	1940380	Vite TCEI M 10x18	Screw	4	Optional
13	1940430	Guida pist. ant.	Front piston guide	3	∅ 20 ● ◆ ○ ■	46	200231	Rosetta	Washer	4	Optional
	1940200	Guida pist. ant.	Front piston guide	3	∅ 22 ▲	47	1941240	Supporto aperto	Open bearing sup.	1	
14	1940470	Guarnizione	Gasket	3	∅ 20 ● ◆ ○ ■	48	1940290	Puleggia	Pulley	1	
	1940480	Guarnizione	Gasket	3	∅ 22 ▲	49	780230	Rondella	Washer	1	
15	1940450	Guida pist. post.	Rear piston guide	3	∅ 20 ● ◆ ○ ■	50	780060	Vite TCEI M 6x25	Screw	1	
	1940460	Guida pist. post.	Rear piston guide	3	∅ 22 ▲	51	1941220	OR ø 22x2	O-Ring	3	Tagliato/Cutted
16	820490	OR ø 34,65x1,78	O-Ring	3		52	390311	Rondella Øi 8,5	Washer	4	
17	1940570	Dado	Nut	3		53	1321670	Boccola	Bushing	6	
18	1940580	Rosetta	Washer	3		54	1380340	Semigiunto motore	Motor coupling	1	
19	1420430	Pistone	Piston	3	∅ 20 ● ◆ ○ ■	55	1380180	Grano M 6x10	Grub screw	2	
	1420120	Pistone	Piston	3	∅ 22 ▲	56	1940890	Flangia motori B3/B14	El. motor flange	1	B3/B14
20	880840	OR ø 9,25x1,78	O-Ring	3		57	620610	Vite TCEI M 8x30	Screw	4	
21	960460	Disco separatore	Spacer	3		58	1940870	Semigiunto pompa	Pump coupling	1	
22	1940120	Anello	Ring	3		59	1949200	Prem.testa	Head pre-assembly	1	∅ 20 ● ◆ ○ ■
23	1940070	Pistone di guida	Guiding piston	3		60	1949203	Prem.testa	Head pre-assembly	1	∅ 22 ▲
24	1940060	Spinotto	Piston pin	3		61	1383080	Flangia motori B3/B14	El. motor flange	1	B3/B14
25	1941380	OR ø 66,34x2,62	O-Ring	2		62	390311	Rondella Øi 8,5	Washer	4	
26	1941390	Spessore 0,05 mm	0,05 mm shim	1÷3		63	1380180	Grano M 6x10	Grub screw	2	
	1941400	Spessore 0,10 mm	0,10 mm shim	1÷3		64	620610	Vite TCEI M 8x30	Screw	4	
	1941410	Spessore 0,19 mm	0,19 mm shim	1÷3		65	1383100	Semigiunto pompa	Pump coupling	1	
	1941420	Spessore 0,25 mm	0,25 mm shim	1÷3		66	1940850	Anello elastico	Ring	1	
27	1949011	Coperchio lat. compl.	Comp. side cover	1		67	1383090	Semigiunto motore	Motor coupling	1	
28	850370	Vite TCEI M 8x16	Screw	8		75	1941270	Livello olio	Oil indicator	1	⊗
29	1941370	Cuscinetto	Bearing	2	●	76	100410	OR ø 34,6x2,62	O-Ring	1	⊗
	1140410	Cuscinetto	Bearing	2	◆ ○ ■ ▲	77	1941260	Disco di contrasto	Disc	1	⊗
30	1940050	Biella	Con-rod	3		78	1941290	Anello elastico	Snap ring	1	⊗
31	1940520	Albero eccentrico	Crank shaft	1	● ◆						
	1940180	Albero eccentrico	Crank shaft	1	○						
	1940160	Albero eccentrico	Crank shaft	1	■ ▲						

## KIT RICAMBI - PART KITS

A=KIT 2780 valvole valves		B=KIT 2650 ø 20 pistoni pistons		B=KIT 1891 ø 22 pistoni pistons		C=KIT 2781 tenute olio oil seals	
Pos.	Q.ty	Pos.	Q.ty	Pos.	Q.ty	Pos.	Q.ty
5	6	19	3	19	3	25	2
6	6					37	1
						42	1
						43	3

## SIMBOLOGIA - SYMBOLS

● Per / For XW 15.15 XW 15.20	○ Per / For XW 21.20 XW 21.25 XW 21.28	■ Per / For XW 26.12 XW 26.15 XW 26.20 XW 26.23	▲ Per / For XW 30.10 XW 30.15 XW 30.20 XW 30.25
◆ Per / For XW 15.30			

⊗ Compreso nel cod. 1949010 / Part of part n° 1949010

⊗ Compreso nel cod. 1949011 / Part of part n° 1949011

D=KIT 2782 ø 20 tenute acqua water seals		D=KIT 2783 ø 22 tenute acqua water seals		G=KIT 2784 ø 20 guida pistoni pistons guide		G=KIT 2785 ø 22 guida pistoni pistons guide	
Pos.	Q.ty	Pos.	Q.ty	Pos.	Q.ty	Pos.	Q.ty
12	3	12	3	13	3	13	3
14	3	14	3	15	3	15	3
16	3	16	3				
51	3	51	3				

## PARTI SPECIALI IN VITON SPECIAL PARTS

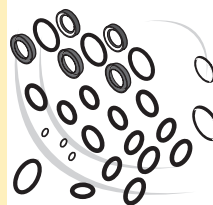

Cod. Part n°	Denominazione Description	Q.tà Q.ty
2778	Tenute acqua/Water seals ø 20	1
2779	Tenute acqua/Water seals ø 22	1

